

A High-Pressure Gas-Scintillation-Proportional Counter for the Focus of a Hard-X-Ray Telescope

R.A.Austin, B.D.Ramsey, C.L.Tse, and C.G. Zirnstein
Space Science Laboratory,
NASA/Marshall Space Flight Center
Huntsville, Al 35812

FAX 256-544-7754
Tel : 256-544-7745

ABSTRACT

We are developing a high-pressure Gas Scintillation Proportional Counter (GSPC) for the focus of a balloon-borne hard-x-ray telescope. The device has a total active diameter of 50 mm, of which the central 20 mm only is used, and is filled with xenon + 4% helium at a total pressure of 10^6 Pa giving a quantum efficiency of greater than 85% up to 60 keV. The detector entrance is sealed with a beryllium window, 3-mm thick, which provides useful transmission down to 6 keV, well below the atmospheric cut-off at balloon float altitudes. Scintillation light exits the detector via a UV transmitting window in its base and is registered by a Hamamatsu position-sensitive crossed-grid-readout photomultiplier tube.

Initial testing is underway and preliminary measurements of light yield, energy resolution and spatial resolution will be reported. Simulations show that a spatial resolution of 0.5 mm FWHM or better should be achievable up to 60 keV, and this is well matched to the angular resolution and plate scale of the mirror system. The energy resolution has been measured to be around 5% at 22 keV.

Full details of the instrument design and its performance will be presented. A first flight is scheduled for the Fall of 99, on a stratospheric balloon to be launched from Fort Sumner, New Mexico.

Keywords : X-ray, astronomy, GSPC, proportional counter, imaging, telescope

1. INTRODUCTION

A novel hard x-ray telescope using replicated, grazing-incidence optics is being developed at NASA's Marshall Space Flight Center. This telescope, named HERO (acronym for High Energy Replicated Optics), is scheduled to be flown via high-altitude balloon in the Fall of 1999. The use of high quality optics in a balloon-borne X-ray experiment places stringent requirements upon the imager. The detector must have high quantum efficiency up to the mirror cut-off of 70 keV, good energy resolution, an ability to efficiently reject background radiation, and sufficient spatial resolution to oversample the 0.8 mm mirror half-power diameter by at least a factor of two. The imager must also be rugged and require no active cooling in order to minimize power consumption and weight. We have concluded that a High-Pressure Imaging Gas Scintillation Proportional Counter (HP IGSPC) is best suited to this task. We will describe our work on such a detector that we are developing to serve as an imager for the HERO telescope.

2. INSTRUMENT FUNCTION AND DESIGN

As can be seen in figure 1, the operation of the HERO imager is very simple in principle. An incident x-ray photon passes through a beryllium window into a region (absorption region) where the photon is photoelectrically absorbed. An electron (photoelectron) which has been liberated by the interaction causes ionization through multiple collisions with atoms of the gas (10 ATM, 96%Xe/4%He) filling the chamber. The electrons liberated by these collisions drift along a moderate electric

field ($\sim 120\text{Vcm}^{-1}\text{atm}^{-1}$) into a region of higher field strength (scintillation region, $\sim 120\text{Vcm}^{-1}\text{atm}^{-1}$), defined by two highly transparent (95% transmission) nickel grids, and produce ultraviolet light through excitation of the fill gas. This light, with a characteristic frequency of 1800\AA , escapes from the chamber through a 7mm thick UV transmitting window (Suprasil[®] 1) and is then detected by a position sensitive photomultiplier tube (PMT). Under typical operating conditions a 60 keV photon will give rise to approximately 10^4 photons incident on the imaging PMT. A charge centroiding algorithm determines the location for each event in the focal plane. This position information, apart from being essential for imaging, is also used to correct for gain variations across the PMT surface.

The HERO HP GSPC will feature a unique design which reduces the high voltage burden on electrical feedthroughs and allows independent control of the drift field. This will be accomplished by splitting the bias voltage such that a negative high voltage will be applied to the beryllium entrance window, the upper grid of the scintillation region will be run at ground and the lower grid will be operated at positive high voltage.

To reduce the risk of electrical shock on the ground and coronal discharge during flight, the beryllium entrance window will be hermetically sealed off from the outside by another beryllium window. The two windows will be electrically isolated by a ceramic collimating tube, and the void between the windows will be filled with 1 ATM of dry nitrogen (fig. 2,3).

The detector also benefits from an extremely hygienic design featuring all metal, ceramic, and glass construction with only one main seal; all other major joints are welded together. An electrically activated getter will maintain cleanliness of the fill gas and thus preclude the need to periodically replace the fill gas as is the case with typical gas filled detectors. With such a design, we expect stable operation over many years. This is an important advantage since we can be confident our calibration will be reliable over the entire course of a balloon flight, especially in the future when extremely long duration (100+ day) balloon flights will be feasible.

The light distribution emerging from the chamber will be imaged by a Hamamatsu 2486 imaging PMT. Though this tube utilizes a 16 X 16 channel crossed-grid readout, successive groups of four readout channels are ganged together in order to reduce, by a factor of four, the total number of channels which must be analyzed. Monte Carlo studies have shown that by such a grouping of signals we can achieve a significant reduction in bandwidth and electronic complexity without significant impact upon position resolution (fig. 4). The output signals from the PMT (4 x-channels, 4 y-channels) are each digitized over a $20\ \mu\text{s}$ interval at a sample rate of 5 MHz. Such complete knowledge of the signal shape and amplitude allows the possibility for background rejection based upon risetime discrimination and signal amplitude distribution.

The variation of solid angle with event location results in a shift in the apparent location with respect to the actual location of the event. To correct for this image distortion, the detector was modeled by Monte Carlo. Apparent x and y positions were plotted against the actual positions (fig. 5). A polynomial fit to the resulting curve was used to correct the actual data. Since the solid angle for light collection varies with event location (fig. 6), the measured energy was similarly corrected.

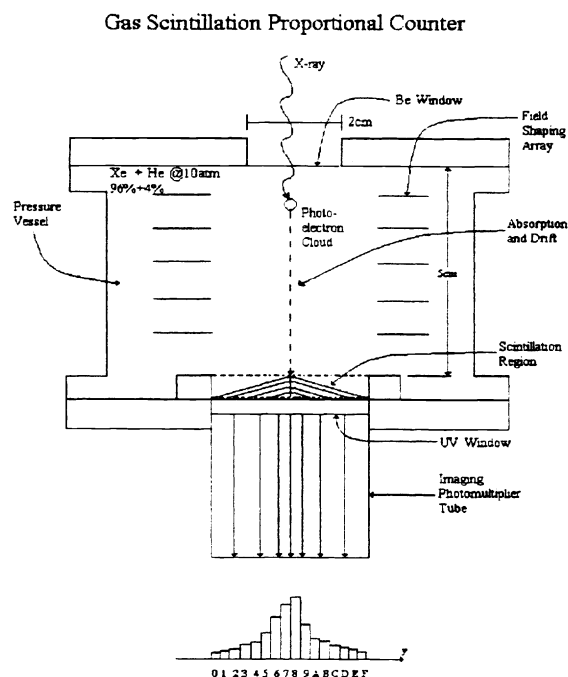

Figure 1 Schematic of HERO prototype detector

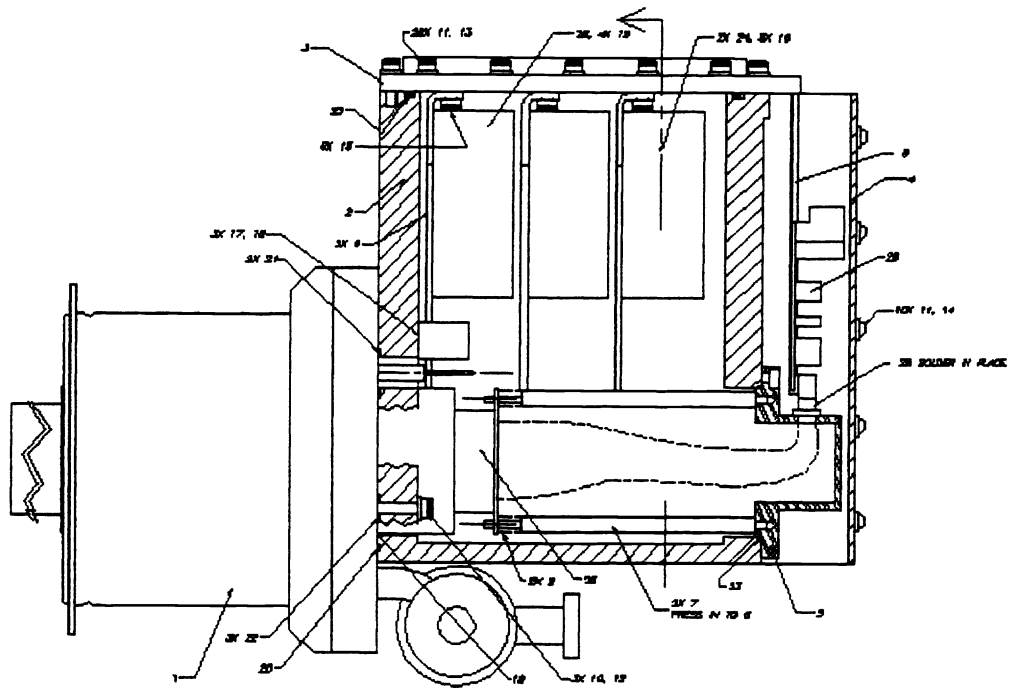

Figure 2. Overall view of a HERO detector system showing the collimator, pressure vessel, and electronics housing.

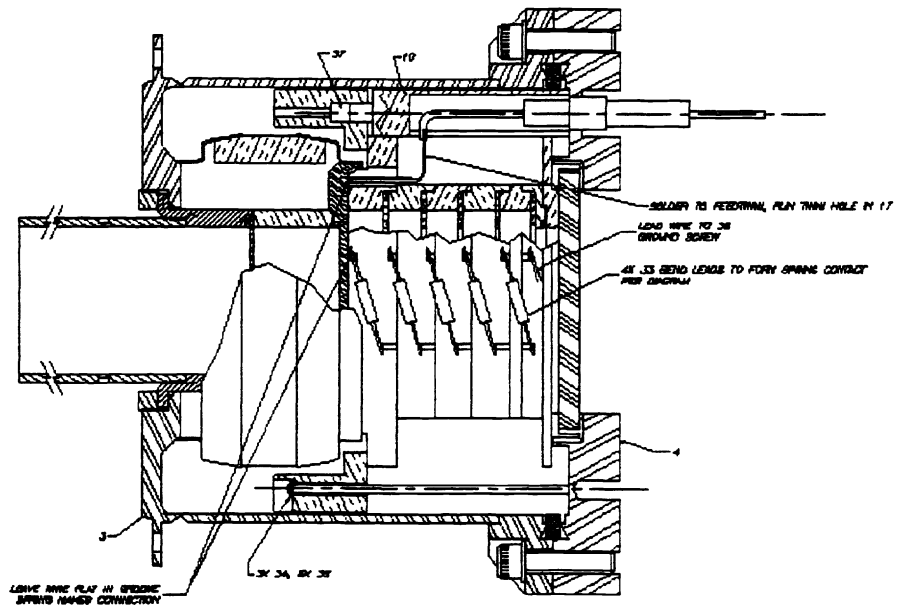

Figure 3. Cross sectional detail of the pressure vessel of a HERO detector showing the collimator, external beryllium window, beryllium entrance window, drift rings and resistors.

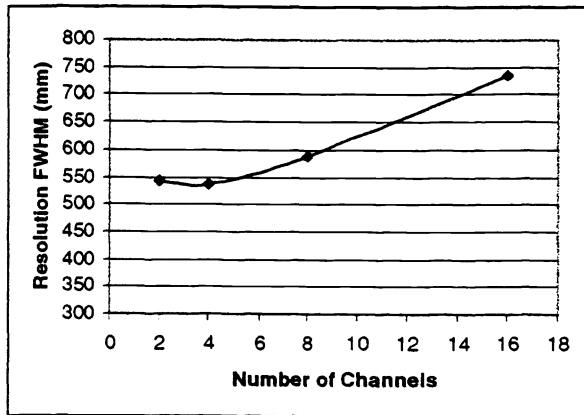

Figure 4. A graph obtained from a Monte Carlo simulation of the HERO prototype detector showing the dependence of position resolution upon the number of x and y channels used in the imaging PMT. The simulation was run for ~3500 detected photons.

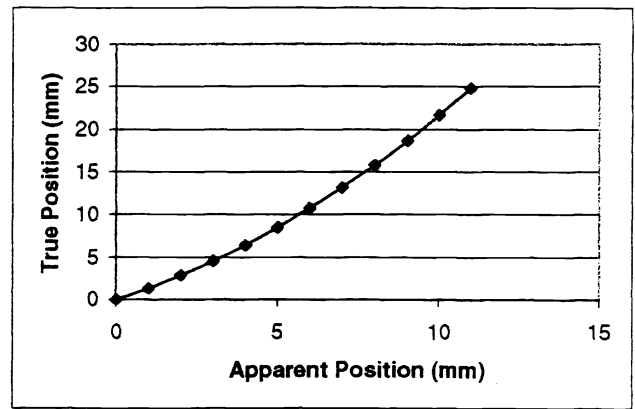

Figure 5. A graph of true event location vs. observed event location obtained from a Monte Carlo simulation of the HERO prototype detector.

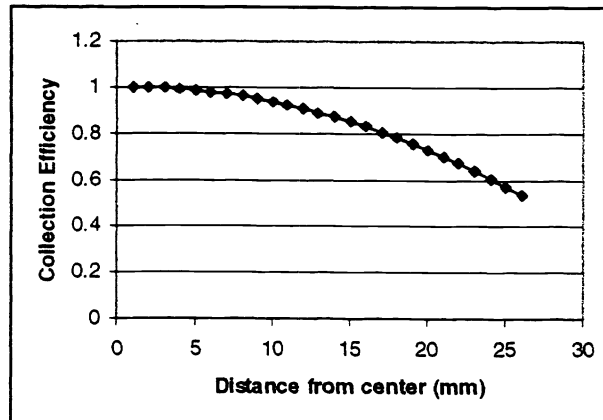

Figure 6. A graph the light collection efficiency as a function of position obtained from a Monte Carlo simulation of the HERO prototype detector.

3. PERFORMANCE

Preliminary measurements of energy and position resolution have been obtained with a prototype HP IGSPC pictured in Figure 2 at left. Energy resolution measurements were performed with an ^{241}Am source which provided an x-ray line at 60 keV and escape peaks at around 30 keV. Position resolution measurements were obtained by measuring the size of an X-ray spot formed by passing a highly collimated beam of continuum X-rays (30 – 50 keV) from an electron-impact source through a pinhole having a diameter $\sim 400\mu\text{m}$. From this measurement, we measured a position resolution (FWHM) of $\sim 500\mu\text{m}$ (see fig. 8). Our results are summarized, along with important HERO detector parameters, in Table 1 below.

Our measured energy resolutions were: 5.2% for the 30 keV escape peak and 3.8% at 60 keV (see fig. 9) Due to breakdown in the detector, the operating voltage was limited to 6100V across the 4mm wide scintillation gap. From a light yield calibration, we estimate that absorption of a 60 keV X-ray results in 3900 photoelectrons in the photomultiplier tube. We are therefore operating in a regime where the energy resolution is dominated by counting statistics. Assuming a Fano factor of 0.17 for Xenon, one can expect to attain an ultimate resolution of 2% at 60 keV. We would have to increase the light yield of our detector by a factor of 3.5 to approach this theoretical limit. Although energy resolution will almost certainly improve with increased light output, our Monte Carlo simulations suggest negligible gains in spatial resolution. The flight units which are currently being built feature a much more hygenic design and electrical breakdown should not be the problem it has been with the laboratory prototype. Higher operating voltages along with a more favorable geometry for light collection assure that these flight units will have position and energy resolution rivaling the results achieved by groups using GSPCs operating at lower pressures¹⁷.

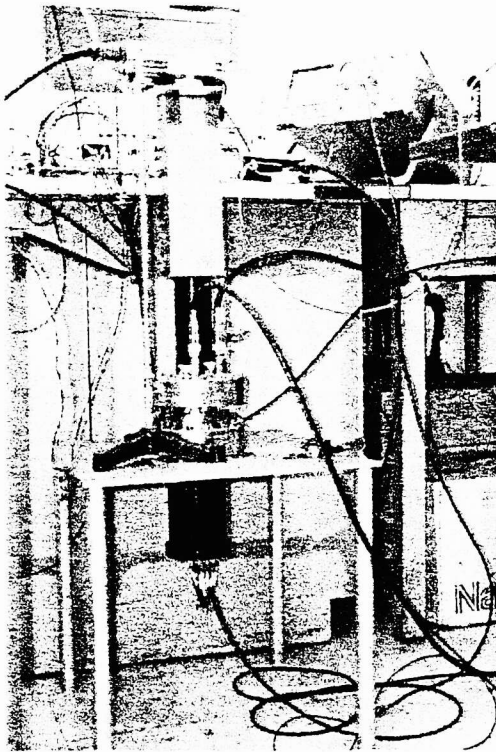

Figure 7. HERO prototype detector undergoing test

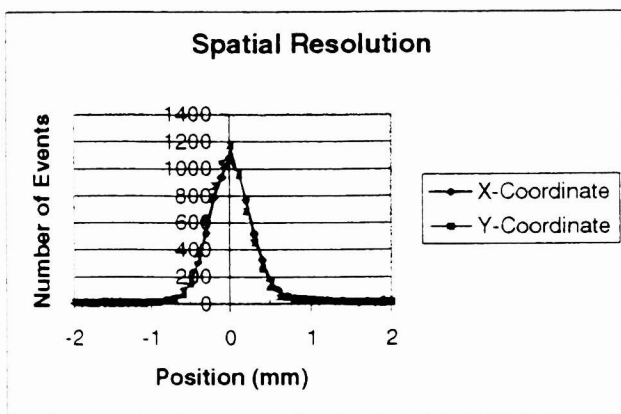

Figure 8. The position resolution measured for the HERO prototype GSPC.

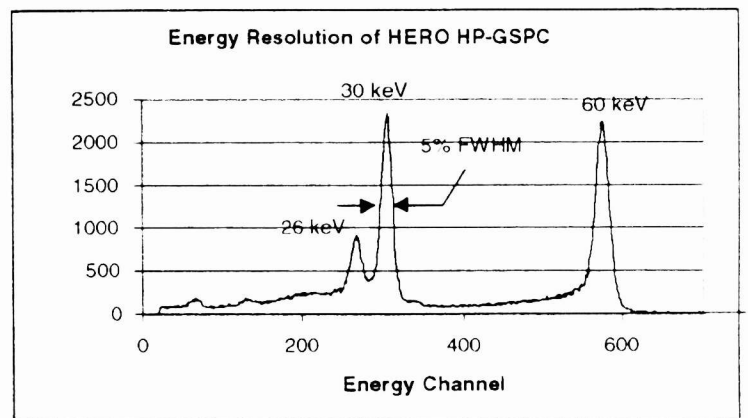

Figure 9. The spectrum obtained from ^{241}Am using the HERO prototype GSPC.

Table 1. Parameters of HERO prototype GSPC

| | |
|------------------------------|--|
| Sensitive Area | Approximately 20cm ² |
| Fill Gas | 50 mm of Xenon + Helium (96/4) at 10 ⁵ Pa |
| Entrance Window | 3.2 mm Beryllium |
| Light Emitting Region | 4.0 mm |
| Exit Window | 7.0 mm of Suprasil |
| Phototube | Hammamatsu 2486, position sensitive |
| Quantum Efficiency | 99% @ 40 keV, 73% @ 70 keV |
| Measured energy resolution | 5.2% @ 30 keV, 3.8% @ 60 keV |
| Measured position resolution | 500 μm (30-50 keV) |

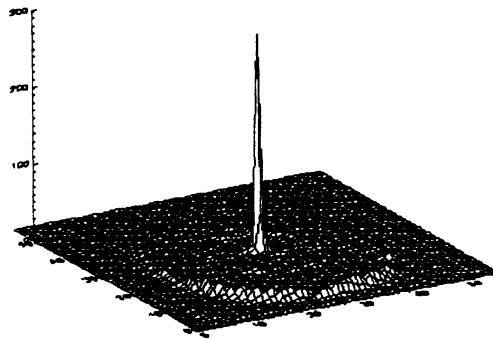

Figure 10. Image of focussed X-Rays using the HERO prototype detector and a replicated hard x-ray mirror. Units are in millimeters.

In May, 1999 the prototype GSPC imager was tested at MSFC's stray light facility in a realistic configuration using a 6m focal length hard x-ray mirror. Continuum x-rays (0-50 keV) were focused by the mirror onto the GSPC. The imaged focal spot was found to have a half power diameter of 1.3mm, in reasonable agreement with expectations, see fig. 10 above. A pinhole scan of the image using a CdZnTe detector found a slightly smaller half power diameter of 1.1mm. The discrepancy is thought to be due to a halo of fluorescence x-rays produced by absorbed x-rays having energies above the K edge of Xenon. We are currently testing this hypothesis by modifying our Monte Carlo program to include this effect.

4. CONCLUSION

Preliminary laboratory results have demonstrated that we can build an HP IGSPC with adequate position and energy resolution to be used as an imager for a hard x-ray grazing incidence telescope. The simplicity, reliability, and ruggedness of this type of detector makes it ideally suited for astronomical observations from a balloon-borne platform.

Flight units for the HERO telescope are presently under construction for a flight scheduled for the Fall of 1999. The design of a flight unit has already been completed. It features an all-metal-seals assembly with built-in getter to ensure stable operation over many years without the need to re-purify the fill gas (the prototype unit, which also contains a getter, has already operated for several months without any discernible gain shifts, despite containing two elastomer seals.) The flight unit also features a novel biasing arrangement wherein the large overall operating voltages, necessitated by the high fill-gas pressure, are split either side of zero by biasing the entrance window at around -8 kV, the upper scintillation grid at 0V and the lower scintillation grid at + 7 kV. This reduces the burden on supplies and feed-throughs and also permits independent fine adjustment of the drift and light yield if required. To accomplish this biasing scheme, the entrance window will be housed in a ceramic isolator to avoid tracking to the grounded body. A second, thin, beryllium window seals the isolator from the outside world with dry nitrogen.

The flight electronics is operational and is currently being used with our prototype detector to gather information needed to optimize software and detector design.

ACKNOWLEDGEMENTS

We gratefully acknowledge Kurt Dietz, Jeff Apple, and Fred Wills for their invaluable contributions to this project.

REFERENCES

1. S. Giarrusso et al., SPIE Proc. 2517 (1995) 234
2. Y. Kohmura et al, SPIE Proc. 2006 (1993) 78